

LPQM, ENS Cachan : G. Lanty, A. Al Choueiry, S. Zhang, E. Deleporte, J.S. Lauret.
 CRHÉA, Valbonne : F. Semond, M. Leroux.
 LPN, Marcoussis : S. Bouchoule, X. Lafosse.
 PPSM, ENS Cachan : P. Audebert.

Context

To reach the polariton lasing regime, the condition $\tau_{relaxation} < \tau_{pol. lifetime}$ has to be satisfied.

⇒ consequently, the quality factors of the microcavities presenting the polariton lasing regime are relatively high (e.g. around 500 for GaN-based microcavities).

⇒ Pb: a high quality factor is not compatible with an important light emission from a polariton laser

Idea

Adding an organic material in a GaN-based microcavity to create a more efficient relaxation channel via the exciton-phonon interaction in the organic material.

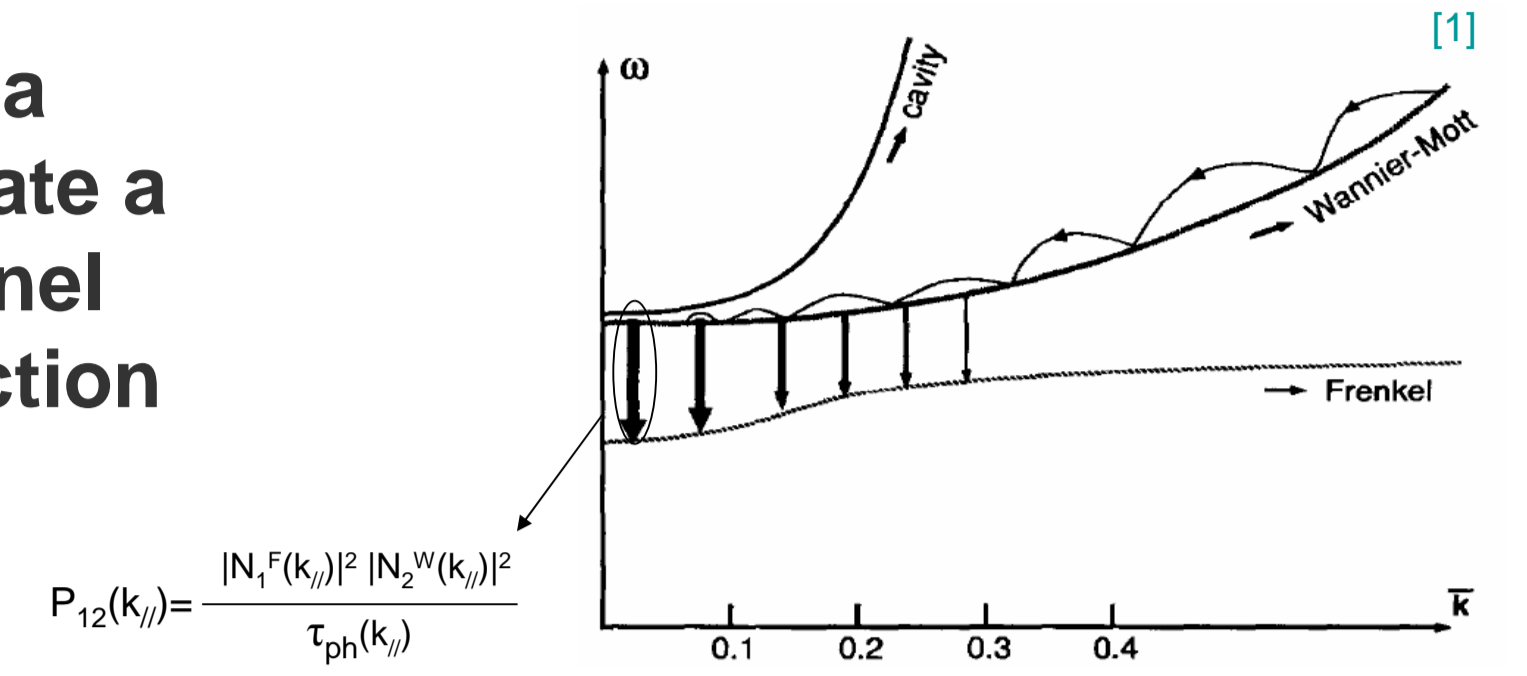

⇒ $\tau_{relaxation}$ should be diminished of a factor 10 at least.

[1] V. Agranovich et al, Solid State Comm. 102, 631 (1997)

The organic material: 2D perovskites

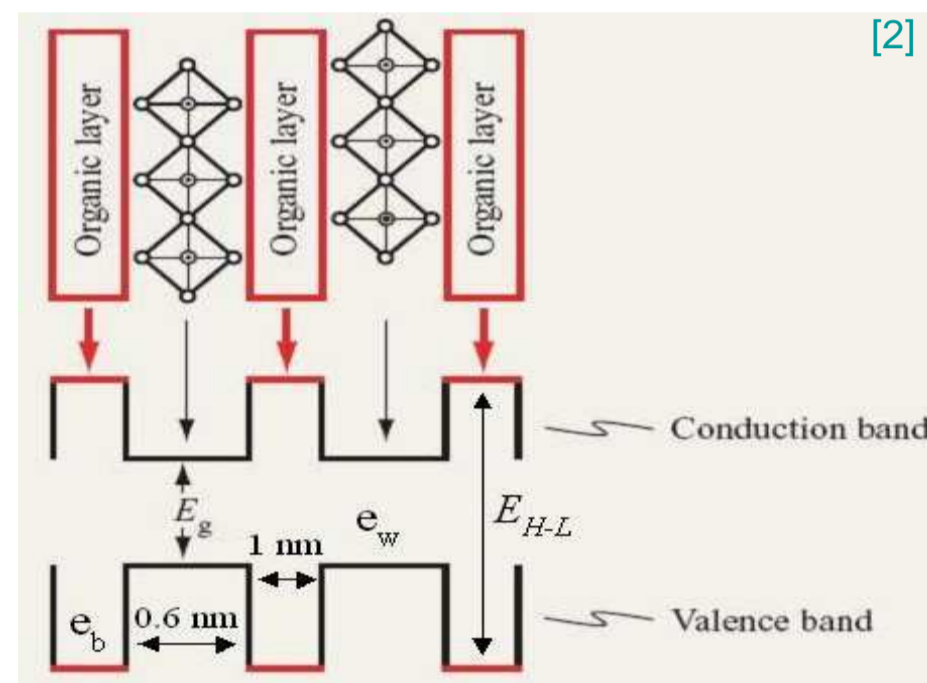
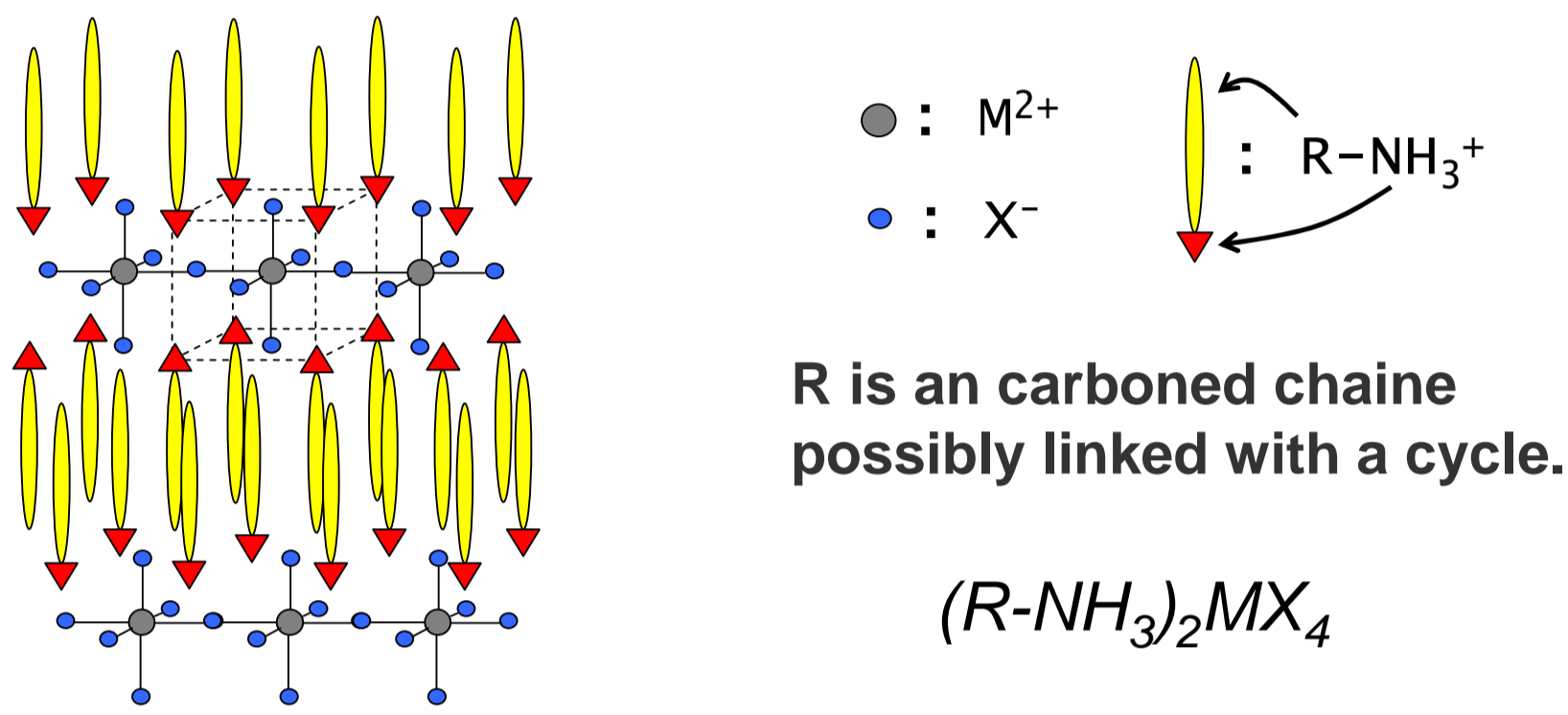

[2] D.B. Mitzi et al., IBM J. Res. & Dev. (2001)

Quantum confinement $E_{H-L} \gg E_b$
 + Dielectric confinement $\epsilon_w \gg \epsilon_b$
 ⇒ $E_{binding} \approx$ de 220 à 480 meV ⇒ Strong excitonic effects at RT

⇒ The exciton energy can be tuned

⇒ Strong coupling regime observed at room temperature for two different perovskite (PEPI[3] and PEPaC[4])

[3] G. Lanty et al., New Journal of Physics, 10 065007 (2008)

[4] G. Lanty et al, Appl. Phys. Lett., 93, 081101 (2008)

First hybrid microcavity

⇒ Structure and fabrication

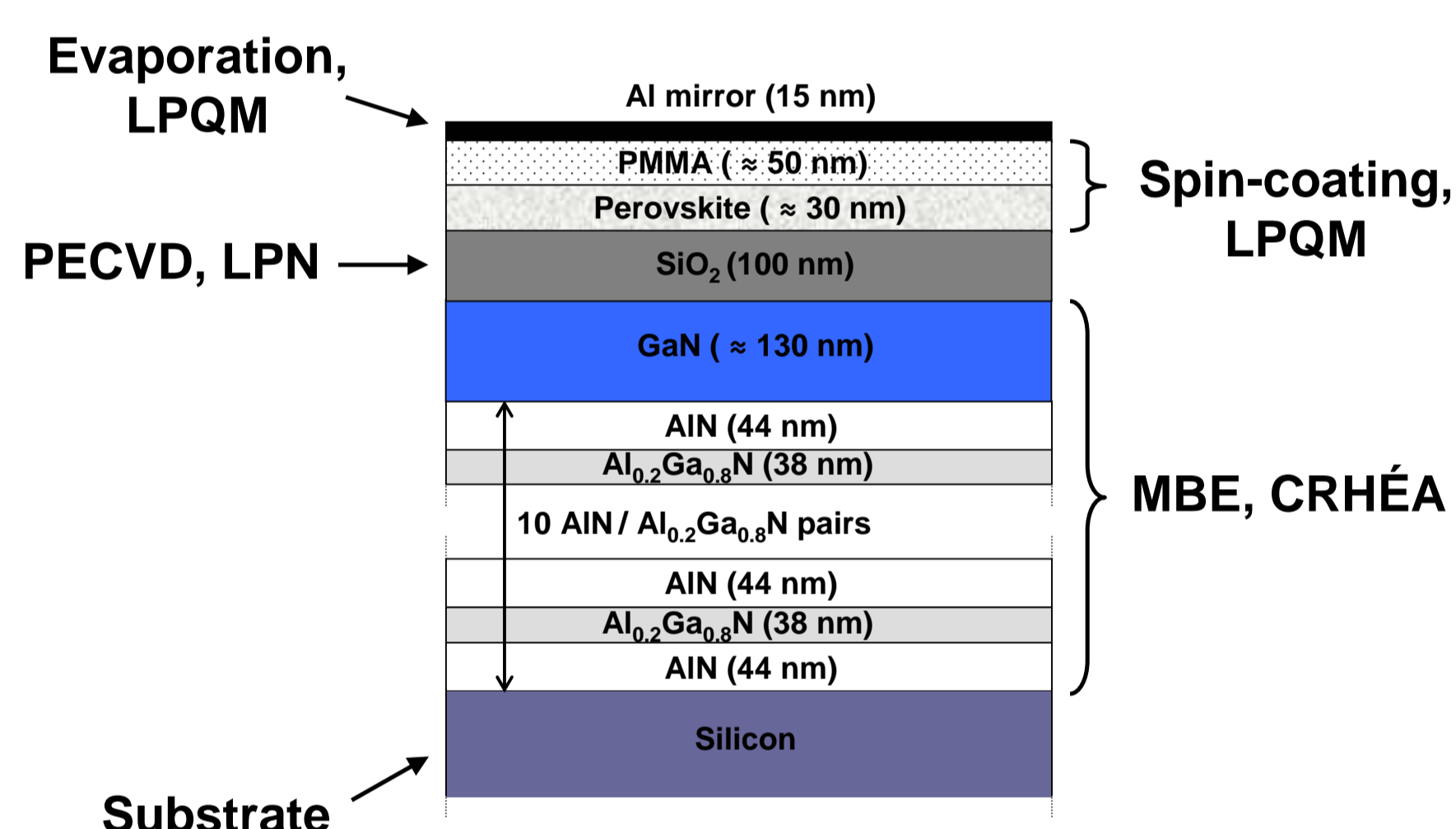

⇒ Electrical field inside the microcavity

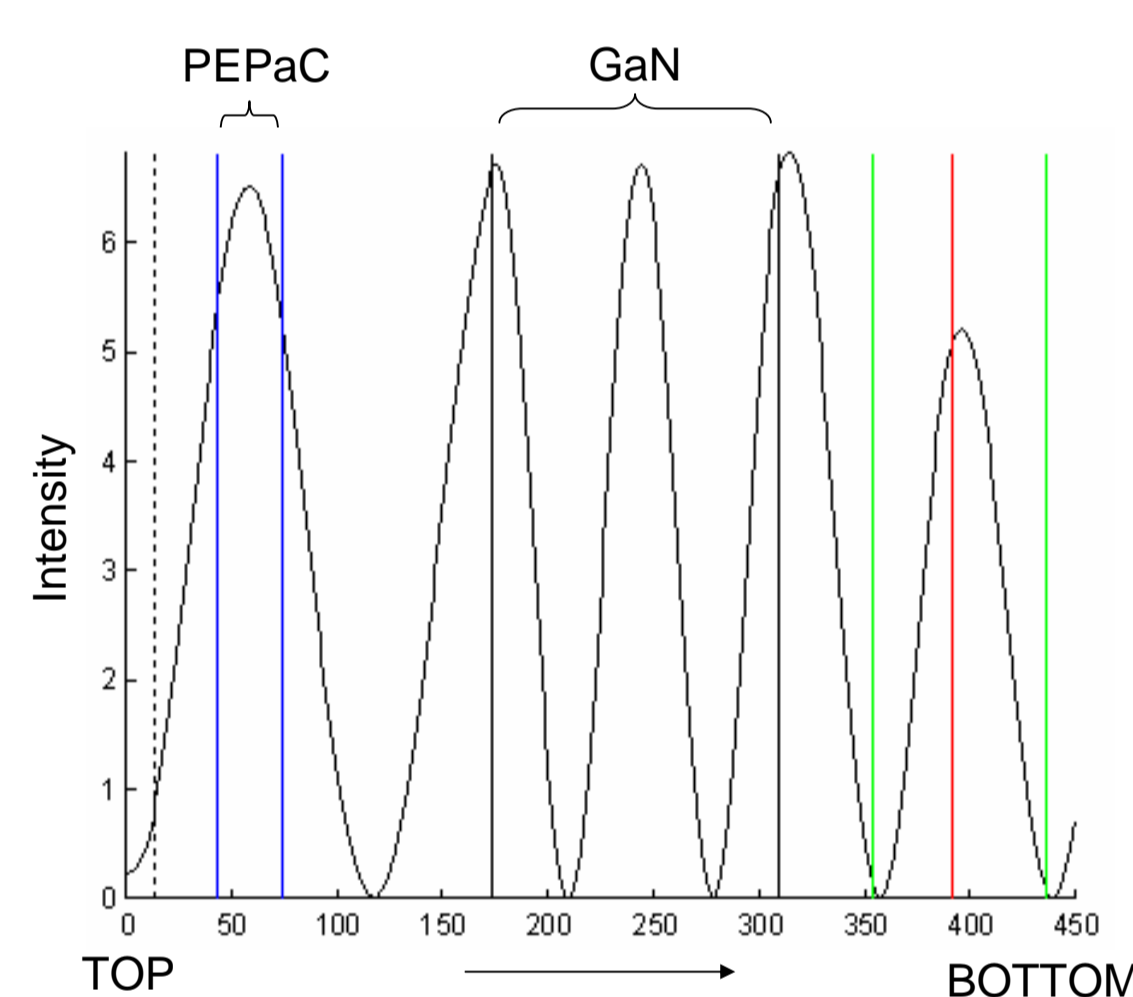

⇒ Angle-resolved reflectivity spectra

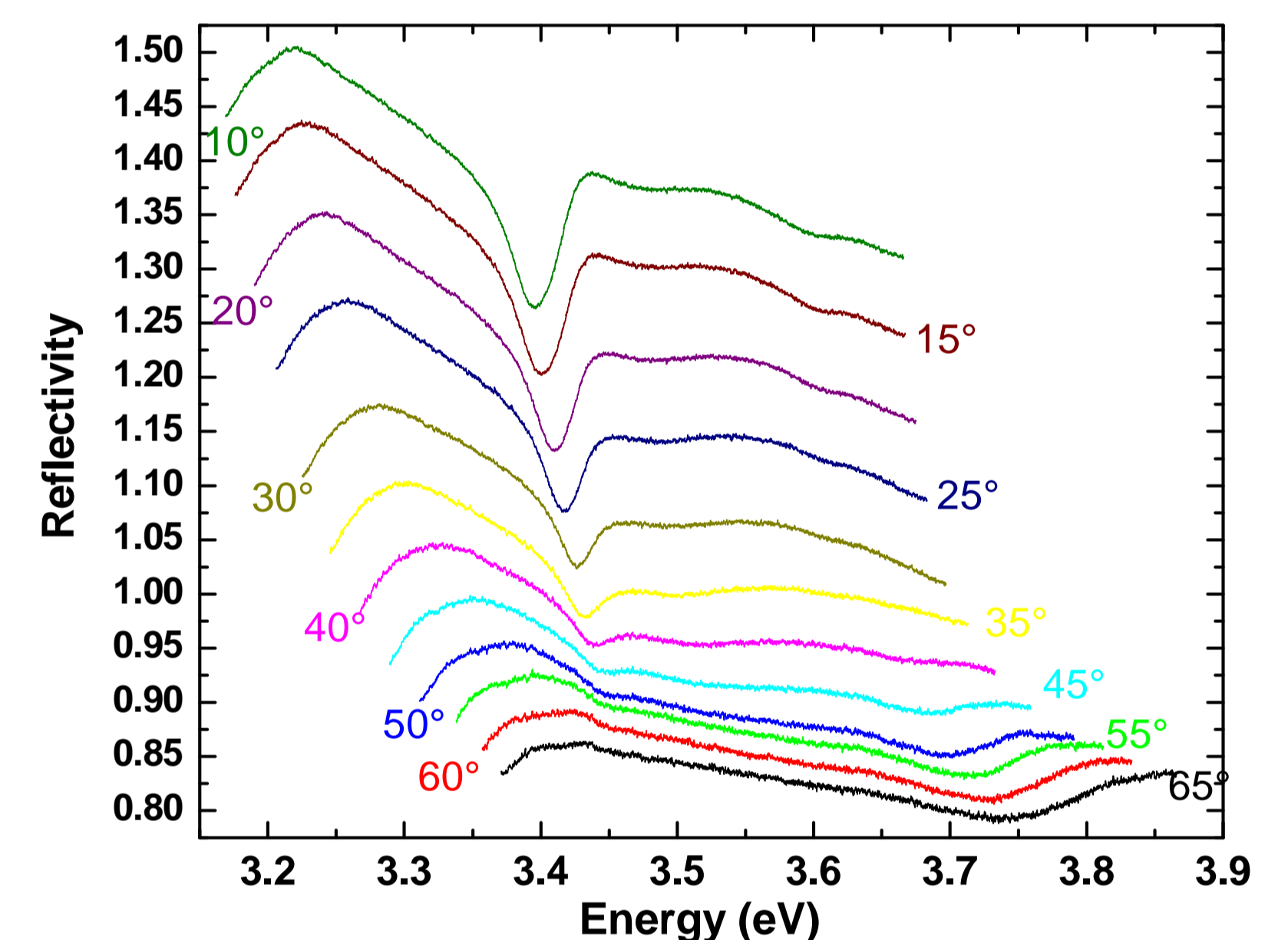

⇒ Anticrossing diagram

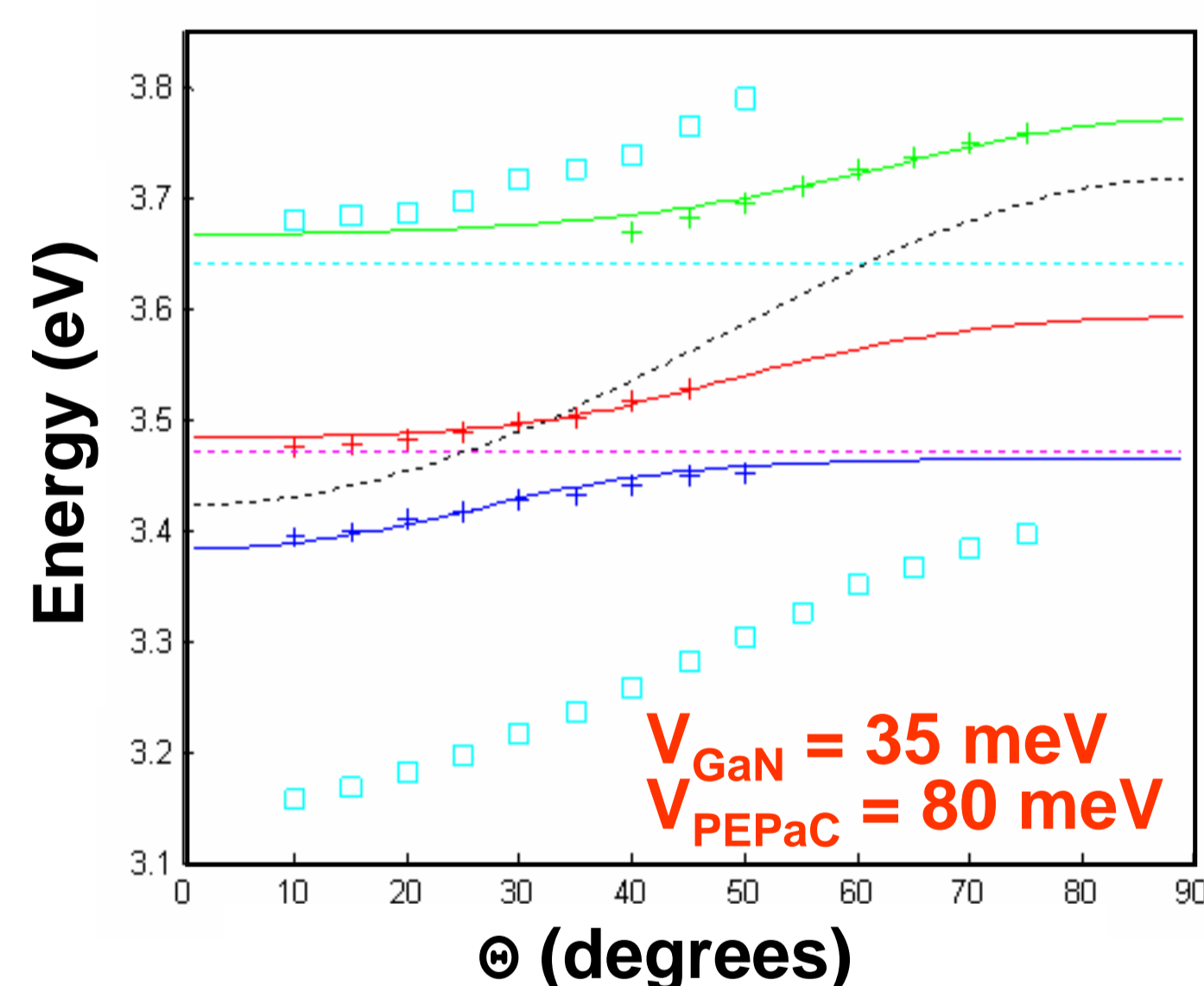

Conclusion

⇒ The first structure realized with GaN and PEPaC has demonstrated that the strong coupling regime can be reached between the two kinds of excitons and the cavity mode.

Prospects

⇒ Realization of the structure proposed by [1]

⇒ Replacing the Al mirror by a dielectric one in order to increase the quality factor of the microcavity.

Several other topics in MICHRY program



Collaboration PPSM/LPQM
 Synthesis of new perovskite luminescent nanoparticles in the visible range (green: Iodide based nanoparticles, blue: Bromide based nanoparticles) [5].

[5] P. Audebert et al, Chem. Mater. 21, 210 (2009)

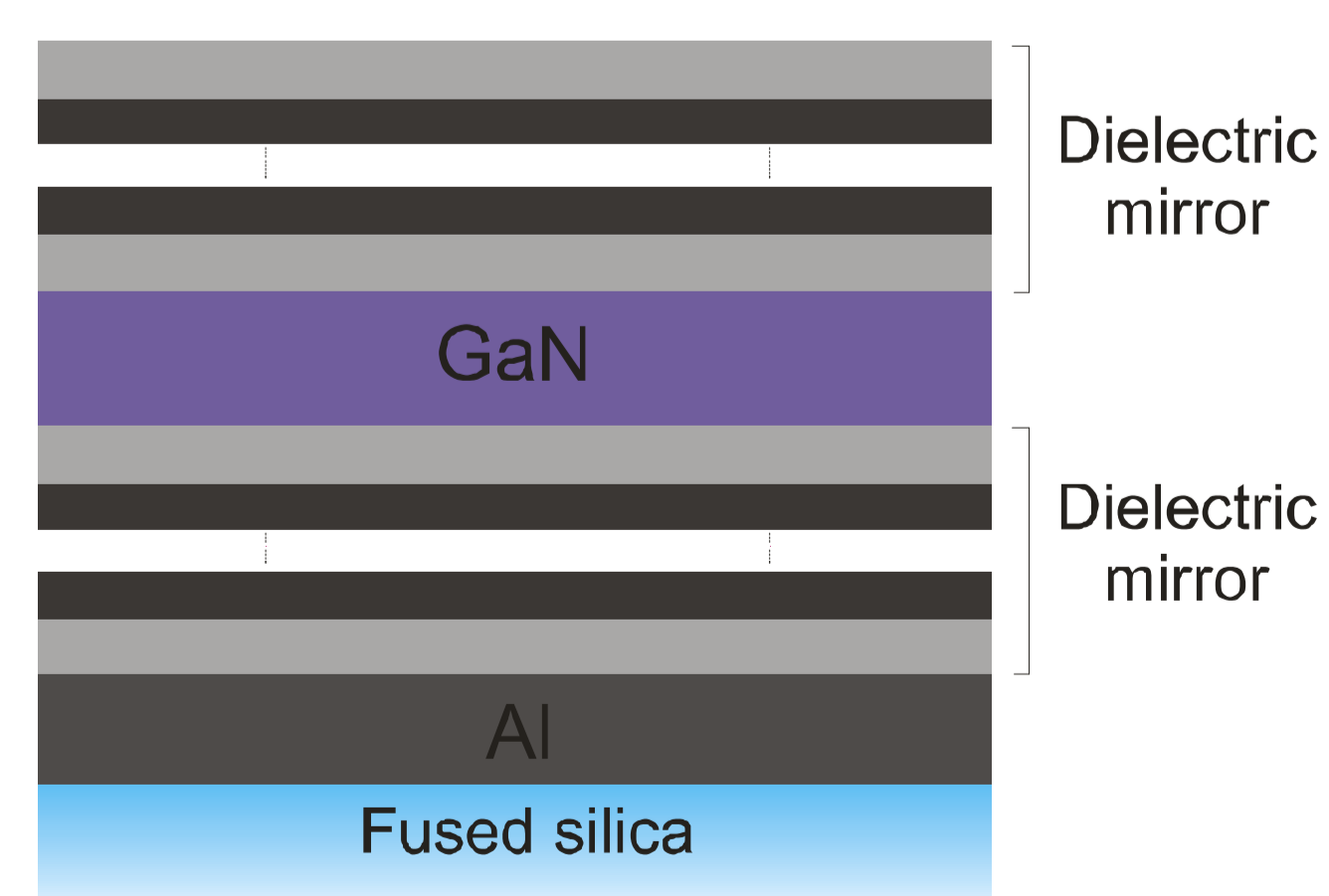

Collaboration LPN/CRHEA
 Realization of GaN microcavities with high quality factors ($Q \approx 500$).